

# Tetra® miniStrip, Tetra® miniStrip DS LED Lighting System

(12 Volt: GEWHBSP3, GEWWBSP3-50K, GEWWBSP3-41K, GEWWBSP3, GEBSH71-1, GEBSH50-1, GEBSH41-1, GEBSH32-1, 24 Volt: GEWHBDP6, GEWWBDP6-50K, GEWWBDP6-41K, GEWWBDP6, GEBDH71-1, GEBDH50-1, GEBDH41-1, GEBDH32-1)

## Components

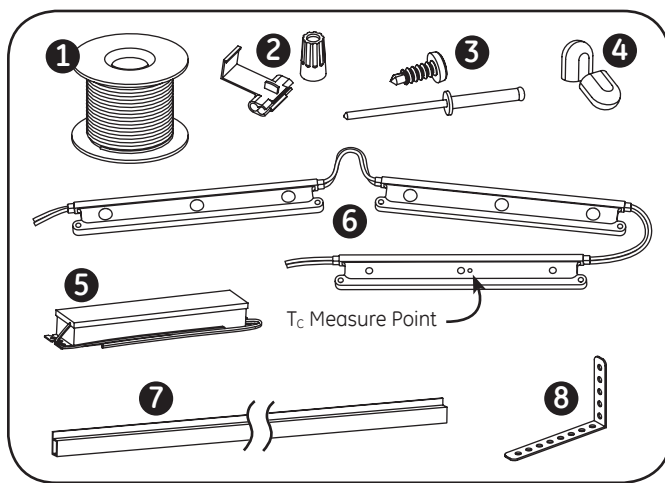

- 1 UL certified 18 AWG (0.82 mm<sup>2</sup>) supply wire
- 2 UL certified 22-14 AWG (0.33-2.08 mm<sup>2</sup>) wire connectors or 18-14 AWG (0.82-2.08 mm<sup>2</sup>) in-line/IDC connectors
- 3 #6 or #8 (M3 or M4) screws, 1/8 inch (3.2 mm) rivets, or electronic grade silicone
- 4 End caps
- 5 Tetra® Power Supply
- 6 Tetra® miniStrip or Tetra® miniStrip DS LED modules

### Optional

- 7 Tetra® Mounting Rail
- 8 Tetra® Mounting Rail Bracket



## BEFORE YOU BEGIN

Read these instructions completely and carefully.

### ! WARNING/AVERTISSEMENT

#### RISK OF ELECTRIC SHOCK

- Turn power off before inspection, installation or removal.
- Properly ground Tetra® power supply enclosure.

#### RISK OF FIRE

- Use only UL certified wire for input/output connections. Minimum size 18 AWG (0.82mm<sup>2</sup>).
- Follow all NEC and local codes.

#### RISQUES DE DÉCHARGES ÉLECTRIQUES

- Coupez l'alimentation avant l'inspection, l'installation ou le déplacement.
- Assurez-vous de correctement mettre à terre l'alimentation électrique Tetra®.

#### RISQUES D'INCENDIE

- N'utilisez que des fils approuvés par UL pour les entrées/sorties de connexion. Taille minimum 18 AWG (0.82mm<sup>2</sup>).
- Respectez tous les codes NEC et codes locaux.

## Save These Instructions

Use only in the manner intended by the manufacturer.  
If you have any questions, contact the manufacturer.

## Prepare Electrical Wiring



### Electrical Requirements

- Limited to use in dry and damp locations.
- The grounding and bonding of the LED Driver shall be done in accordance with National Electric Code (NEC) Article 600.
- Follow all National Electric Codes (NEC) and local codes.
- These products are only suitable for connection to a circuit from a Class 2 power source. These products have not been evaluated for use when connected to a power source that does not comply with Class 2 voltage and energy limited supplies.



imagination at work

## Layout Recommendations

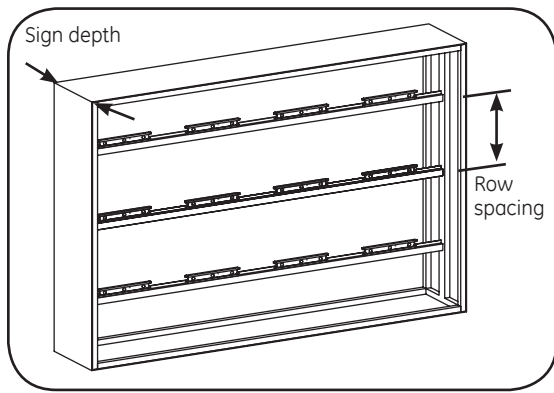

Recommended sign depth is 3-5 in. (76.2 mm-127 mm) for single sided and 6-10 in. (152.4 mm-254 mm) for double sided applications.

Tetra Module	Depth	Stroke Width	Mod to Mod Spacing
Single Sided miniStrip and miniStrip High Output	3-4" (76-102mm)	7" (178mm)	9" (229mm)
	4-5" (102-127mm)	9" (229mm)	10" (254mm)
	5-6" (127-152mm)	11" (279mm)	11" (279mm)
Double Sided miniStrip and miniStrip High Output	6-8" (152-203mm)	7" (178mm)	9" (229mm)
	8-10" (203-254mm)	9" (229mm)	10" (254mm)
	10-12" (254-305mm)	11" (279mm)	11" (279mm)

## Installation: Sign Without Rails

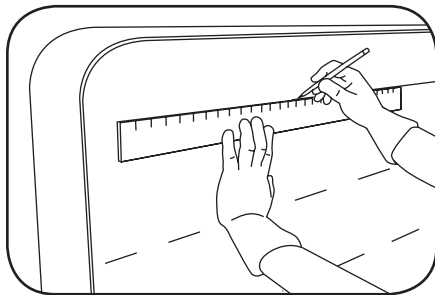

**1** Mark row spacing guidelines so that modules are spaced evenly inside and from edges of sign.

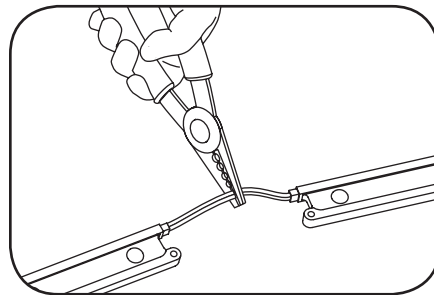

**2** Determine how many modules are required for one row and cut wire.

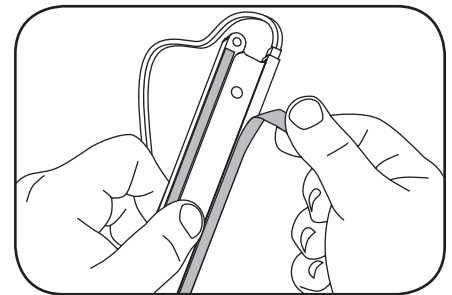

**3** Peel off paper backing to expose adhesive tape.

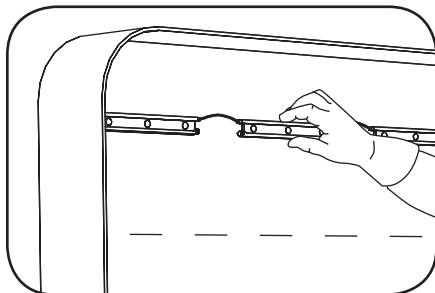

**4** Position string of modules along guidelines and adhere to sign.

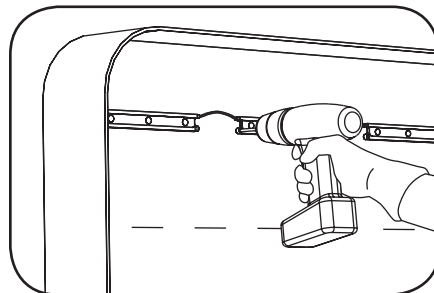

**5** Secure with at least one screw per module with #6 or #8 (M3 or M4) screws or 1/8-inch rivets (3.175 mm), silicone or equivalent.

## Installation: Sign Using Rails

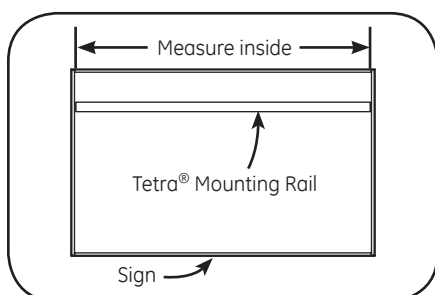

**1** Measure and cut Tetra® Mounting Rail or other suitable mounting means to appropriate length to fit into sign.

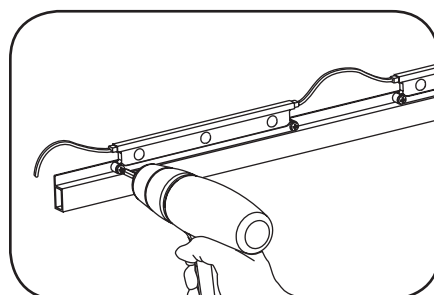

**2** Arrange modules evenly spaced apart. Place the Tetra® modules on the Mounting Rail and secure into place with a self-tapping #6 (M3) screw or 1/8-inch (3.175 mm) rivet.

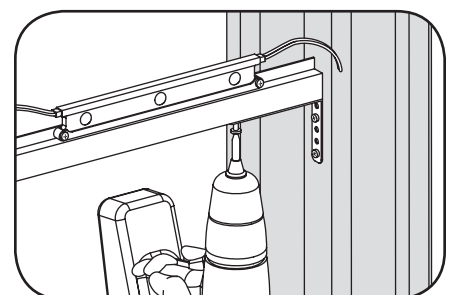

**3** Secure the Mounting Rail to the inside of the box sign using a Tetra® Mounting Rail Bracket or other suitable mounting means. Ensure the #6 (M3) screw does not exceed 3/4 inches (19 mm) in length.

## Electrical Connections

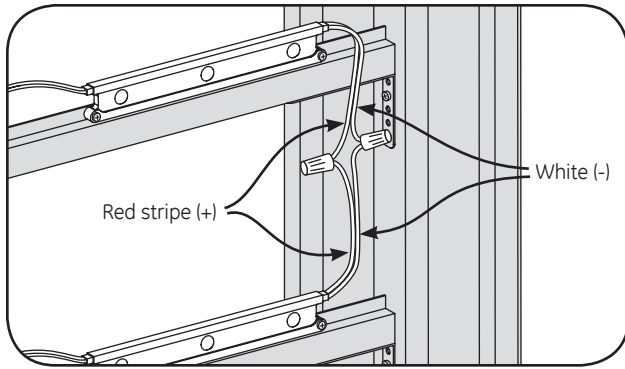

- 1 Connect modules using twist-on wire connectors or in-line (IDC) connectors. Join white wires together and red striped wires together.

**NOTE:** Additional supply wire may be necessary to bridge electrical connections.

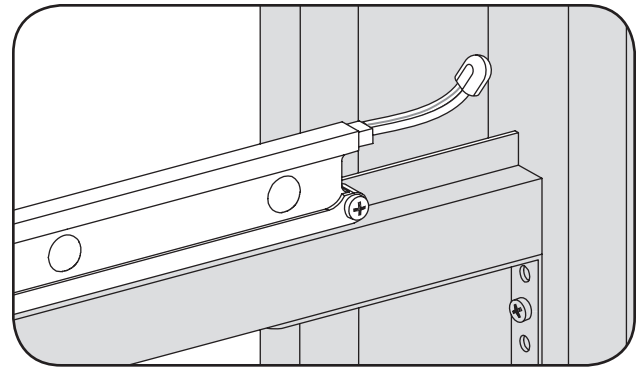

- 2 Cap all exposed wires with appropriate end caps or apply electric grade (non-corrosive) silicone for additional weather protection.

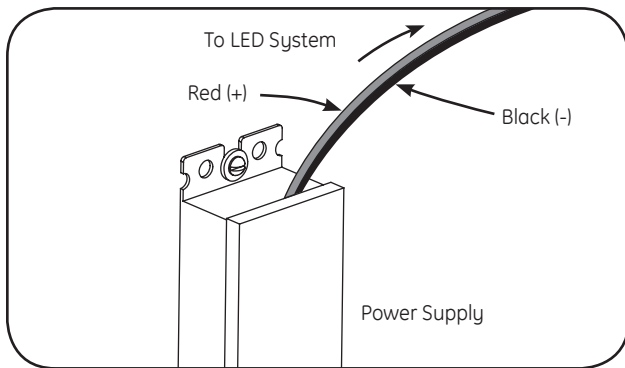

- 3 Run a wire from the power supply to connect to the first module on the strip.

**NOTE:** Exceeding maximum load will cause the power supply to shut down. If overload occurs, remove excess load, recycle the input power to restart the power supply.

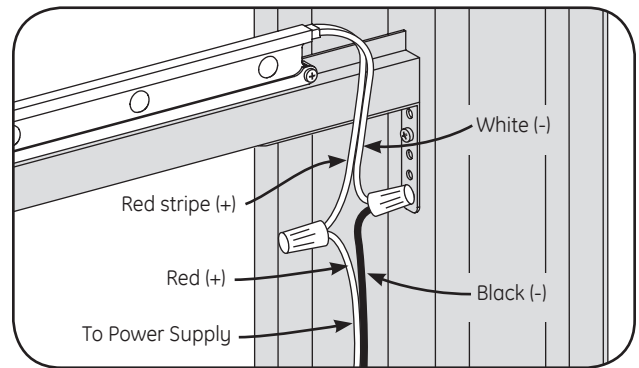

- 4 Connect the red stripe wire (+) of the LED system to the red wire (+) of the power supply. Connect the white wire (-) of the LED system to the black wire (-) of the power supply.

## Retrofit Instructions

1. **(Existing Signs Only)** Prior to installation, survey the site for information regarding power and accessibility inside and outside the building. Ensure that the branch circuit supplying the existing transformer or ballast will be within the voltage ratings of the new LED power supply, and have a current rating not exceeding 20A, or that permitted by applicable local, state, or country electrical codes (whichever is less).
2. **(Existing Signs Only)** Remove the existing lighting equipment to be replaced, such as neon tubing or fluorescent tubes; and associated transformers and ballasts. Care should be taken not to break the existing neon or fluorescent tubes.  
**NOTE:** Follow all federal and local regulations when disposing of neon tubing, fluorescent tubes, transformers and ballasts.
3. **(Existing Signs Only)** If removal of the existing lighting equipment eliminates the disconnect switch, as required by applicable local, state, or country electrical codes; a new disconnect switch must be installed.
4. **(Existing Signs Only)** Make sure the removal of lighting equipment does not compromise the integrity of the sign body (i.e. water intrusion). Fill in all holes 0.5 in. (13 mm) or smaller with the appropriate amount of rated caulk or sealant. For holes greater than 0.5 in. (13 mm), use an aluminum or zinc coated steel patch with rivets and sealant.
5. **(Existing Signs Only)** A clean and dry mounting surface ensures optimum adhesion if the self-adhesive method of mounting is chosen. Follow the manufacturer's directions when using a non-oil based solvent, such as rubbing alcohol to clean the surface area where you intend to mount the module. Before installing, ensure the surface is dry.
6. Using the layout guidelines below, determine required number of LED modules required to illuminate the sign.
7. A Tetra® 12VDC Class 2 Power Supply, as listed below, must be used with a Tetra® MiniStrip (single sided) retrofit kit. A Tetra® 24VDC Class 2 Power Supply, as listed below, must be used with a Tetra® MiniStrip DS (double sided) retrofit kit. Using the Maximum Loading chart below, determine the number of Tetra Class 2 Power Supplies required to power the number of LED modules required to illuminate the sign, so as not to overload the Tetra® Class 2 Power Supply chosen.
8. Follow the instructions above to properly mount the LED modules.
9. Connect the DC output of the power supply to the LED modules using the Electrical Connections instructions above.
10. Connect the power unit to the supply in accordance with the applicable local, state, and country electrical codes, and the instructions found in the power supply installation guide.
11. If required, the disconnect switch shall be installed by qualified personnel, in accordance with applicable local, state, and country electrical codes.

# Troubleshooting

Symptom	Solution
Row of modules does not light	<ul style="list-style-type: none"> <li>Check wire connections to power supply to ensure red stripe-to-red and white-to-black connections.</li> <li>Check row-to-row polarity connections.</li> </ul>
Sign does not light	<ul style="list-style-type: none"> <li>Check input and output voltage and check power supply input/output connections.</li> <li>Check polarity connections.</li> </ul>
Individual modules do not light	<ul style="list-style-type: none"> <li>Remove module and replace with another working module.</li> </ul>
Modules are dim	<ul style="list-style-type: none"> <li>Ensure the overall length of the Tetra® LED system does not exceed the maximum load.</li> <li>Ensure the length and gauge of the supply wire is equal to or below the recommended remote mounting distance.</li> </ul>

## Specifications

### Maximum Loading per Tetra® 12 VDC Class 2 Power Supply

SKU	Rating	20W Power Supply Note: Load shall not exceed 1.6A	60W Power Supply Note: Load shall not exceed 5A	180W Power Supply Note: Load shall not exceed 5A per each (of 3) output channels
GEWHBSP3, GEWWBSP3-50K, GEWWBSP3-41K, GEWWBSP3	12VDC, 1.10W per module	17 modules/17 ft. (5.18 m)	53 modules/53 ft. (16.16 m)	53 modules/53 ft. (16.16 m) per output bank 159 modules/159 ft. (48.48 m) per power supply
GEBSH71-1, GEBSH50-1, GEBSH41-1, GEBSH32-1	12VDC, 1.49W per module	12 modules/12 ft. (3.66 m)	38 modules/38 ft. (11.58 m)	38 modules/38 ft. (11.58 m) per output bank 114 modules/114 ft. (34.75 m) per power supply

### Maximum Remote Mounting Distance

	18 AWG/0.82 mm <sup>2</sup> Supply Wire	16 AWG/1.31 mm <sup>2</sup> Supply Wire	14 AWG/2.08 mm <sup>2</sup> Supply Wire	12 AWG/3.31 mm <sup>2</sup> Supply Wire
20W Power Supply	120 ft./36.6 m	-	-	-
60W Power Supply	20 ft./6.1 m	25 ft./7.6 m	35 ft./10.6 m	40 ft./12.1 m
180W Power Supply	20 ft./6.1 m	25 ft./7.6 m	35 ft./10.6 m	40 ft./12.1 m

### Maximum Loading per Tetra® 24 VDC Class 2 Power Supply

SKU	Rating	20W Power Supply Note: Load shall not exceed 0.83A	80W Power Supply Note: Load shall not exceed 3.3A	100W Power Supply Note: Load shall not exceed 4.0A	180W Power Supply Note: Load shall not exceed 3.8A per each (of 2) output channels
GEWHBDP6, GEWWBDP6-50K, GEWWBDP6-41K, GEWWBDP6	24VDC, 2.20W per module	8 modules/8 ft. (2.44 m)	31 modules/31 ft. (9.45 m)	39 modules/39 ft. (11.89 m)	35 modules/35 ft. (10.67 m) per output channel 70 modules/70 ft. (21.34 m) per power supply
GEBDH71-1, GEBDH50-1, GEBDH41-1, GEBDH32-1	24VDC, 2.98W per module	6 modules/6 ft. (1.83 m)	24 modules/24 ft. (7.32 m)	30 modules/30 ft. (9.14 m)	27 modules/27 ft. (8.23 m) per output channel 54 modules/54 ft. (16.46 m) per power supply

### Maximum Remote Mounting Distance

	18 AWG/0.82 mm <sup>2</sup> Supply Wire	16 AWG/1.31 mm <sup>2</sup> Supply Wire	14 AWG/2.08 mm <sup>2</sup> Supply Wire	12 AWG/3.31 mm <sup>2</sup> Supply Wire
20W Power Supply	120 ft./36.6 m	-	-	-
80W Power Supply	20 ft./6.1 m	25 ft./7.6 m	35 ft./10.6 m	40 ft./12.1 m
100W Power Supply	20 ft./6.1 m	25 ft./7.6 m	35 ft./10.6 m	40 ft./12.1 m
180W Power Supply	20 ft./6.1 m	25 ft./7.6 m	35 ft./10.6 m	40 ft./12.1 m

Conforms to the following standards:



GE Lighting Solutions • 1-888-MY-GE-LED • [www.gelightingsolutions.com](http://www.gelightingsolutions.com)  
1 - 8 8 8 - 6 9 - 4 3 - 5 3 3

GE Lighting Solutions, LLC is a subsidiary of the General Electric Company. Tetra is a trademark of GE Lighting Solutions, LLC. The GE brand and logo are trademarks of the General Electric Company. © 2013 GE Lighting Solutions, LLC. Information provided is subject to change without notice. All values are design or typical values when measured under laboratory conditions.